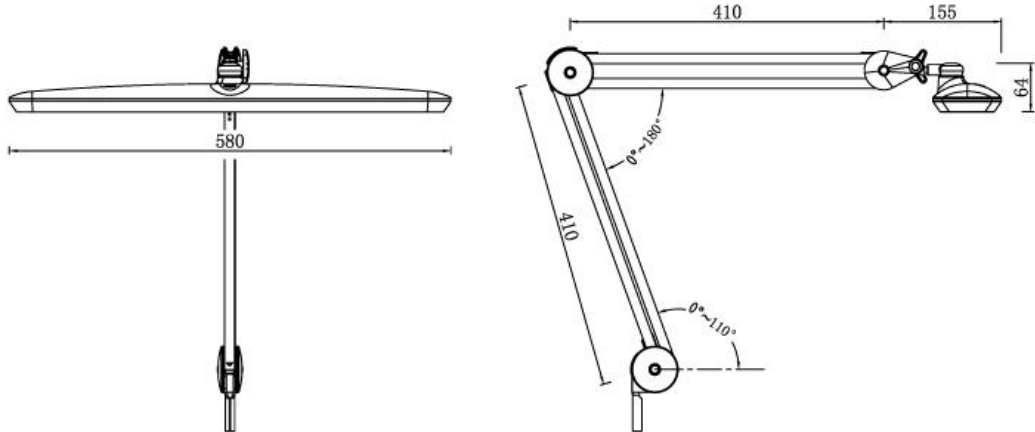

CHUTONG ELECTRIC CO LIMITED

Led Work light

| | |
|---|---------------------|
|  | Item number:CH51WK |
| | Swing Arm: 410MM *2 |
| | 12W 1200LM |
| Switch: Non dim/Dimmable White/ESD black | |
|  | |

Product Description

An industrial quality daylight balanced task light.

Features a long 41cm*2 shade and a long-reach swing arm designed for any work bench or desk. Great for inspection of small parts, stamp collecting, crafts and hobbies

Features:

41cm*2 Spring Balanced Swing Arm stays set in any position.

clamp for mounting to desk, workbench, table, etc.

Industries usage Mfg, Assembly, Inspection, QA, Scientific, Medical, Forensics, etc.

110/220V-60Hz; 5-foot power cord. For indoor use only.

CHUTONG ELECTRIC CO LIMITED

Spare parts

