

# CHUTONG ELECTRIC CO LIMITED

## Magnifying led lamp-with white light

	Item number CH127ESD Lightness: white Body: black color ESD Arm 410mm*2 With clamp lens:127mm magnification: 5 diopter
	White lightness Clamp base ESD black body  14W led lightsource None dim

### Magnifying lamp application

1 suitable for circuit board inspection, processing, installation at electronics industry. Electronic engineers to observe and test the micro elements, components of dense circuit board

2 suitable for engraving, fine operation and observation.

3 suitable for simple surgical operation. Enlarge the lighting for beautician and medical staff

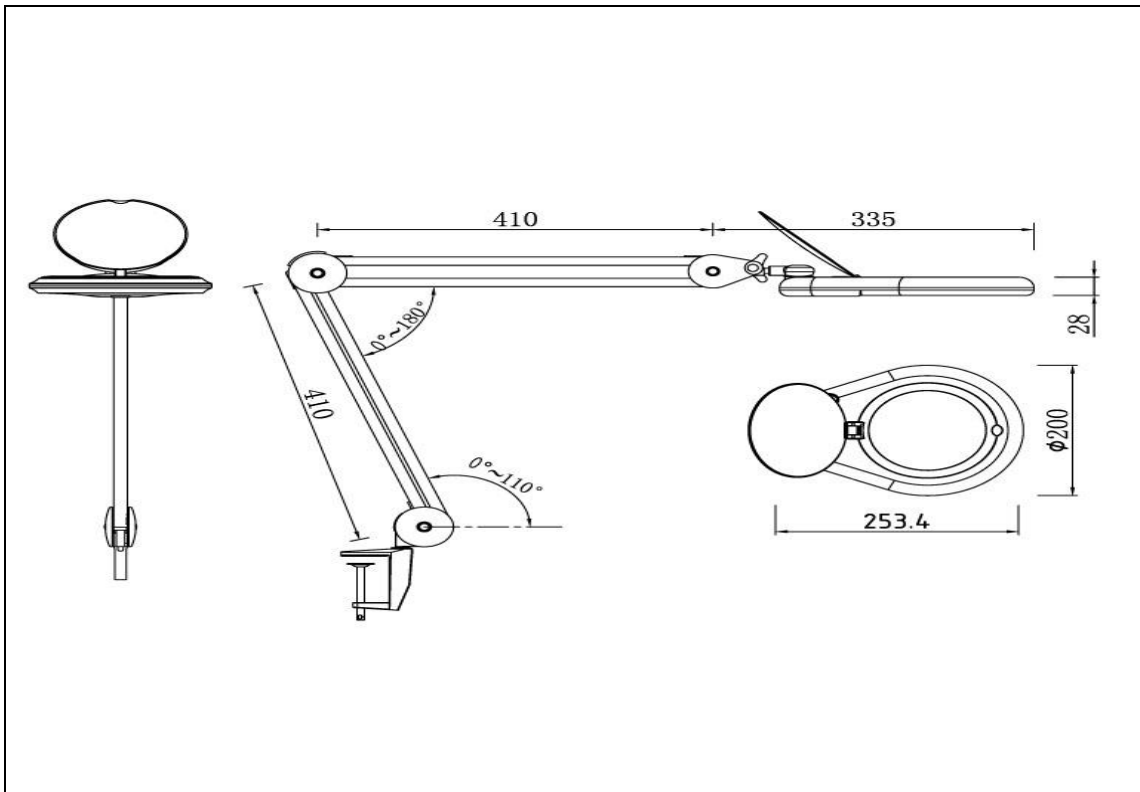

# CHUTONG ELECTRIC CO LIMITED

---

Magnifier lamp Features:

3D5D8D Diopter Magnification

5inch6inch7inch Clear and illuminating magnifying lens with protective cover

The lens head can rotate left and right with 360 degrees and flip up and down 180 degrees

Soft cool bulb for natural color and shadow-free magnification

Power on and off switch

Articulated arm ,no visible springs, Hydraulic look

Conveniently adjustable height and arm for magnification in any position

The dimmable dimmer allows you to easily adjust the brightness level to achieve the perfect lighting for drawing, reading, arts & crafts, sewing, needlework, working, and studying.

Available body color in Black and White.

Magnifying lamp application

1 suitable for circuit board inspection, processing, installation at electronics industry. Electronic engineers to observe and test the micro elements, components of dense circuit board

2 suitable for engraving, fine operation and observation.

3 suitable for simple surgical operation. Enlarge the lighting for beautician and medical staff

4. circuit board test, stamp collector, infirmary, beauty parlor, reader, amateur, enginee

